

# ADIS

A U T O M A T I C   D O O R S

I N T R O D U C E S

## ADIS SAFETY DOOR SYSTEM



**Flush glazed slimline doors and frames**

The AUSTRALIAN Automatic Door Company

AS 5007 Compliant

# ADIS SAFETY DOOR SYSTEM

## Door and Frame Specification

The doors and sidelights for the automatic door entry screen shall be constructed from ADIS narrow line safety door system, designed to conform to the new Australian Standard for Automatic Doors AS 5007.

The framing system shall contain the following features and advantages to guide against the hazards associated with Automatic sliding doors,

1. The frame vertical profile in elevation shall be no wider than 32mm. This shall maintain a near frameless slim look.
2. The doors and frames shall have a complete seal system on all 4 sides of the doorway to ensure total closure of the opening against the extremes in climate, dust and wind.
3. Joints between the door and fixed sidelights are to be overlapping and interlocking, in addition the maximum width of a joint gap shall not exceed 6mm, to ensure minimal draw in hazard.
4. Frames and doors are required to be flushed glazed, this will ensure that both draw in and shear hazards are minimized below accepted norms.
5. The leading edges of each door are to be fitted with PVC buffer strips to help protect the door finishes and to give increased weather seal whilst doors are closed.
6. The frames are to be built to accept various thicknesses of glass ranging from 10mm to 15mm, this will ensure the safety of the public and allow the door system to be suitably utilized on many applications in size of glazed screens and the wind loads that may vary in various location through out Australia.
7. The ADIS electric lock system is to utilized to secure the doors manual locking devices are not to be accepted.

Option. An internal safety screen is available to assist with minimization of body and head entrapment directly behind the doors path of travel, this panel is pivoted to allow access for cleaning.

Capable of accepting  
10mm to 15mm Glass to suit  
high wind zones



Security airlocks with sleek design.



Suitable for doorways used by children.



Designed for safer disabled access.



Allows maximum door opening.

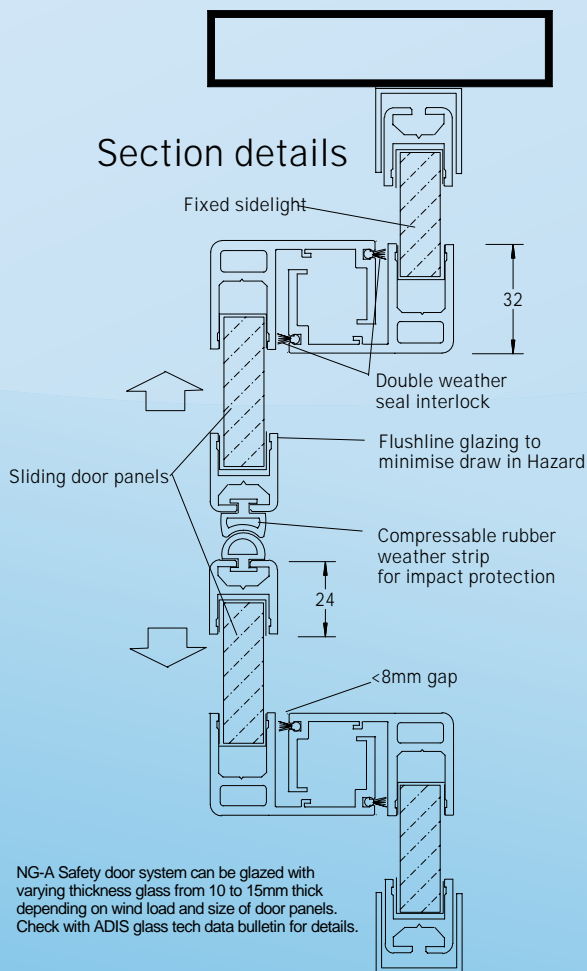

## ADIS Safety Door System Minimises:

- Finger entrapment
- Draw in hazard
- Shear hazard
- Body and Head Entrapment

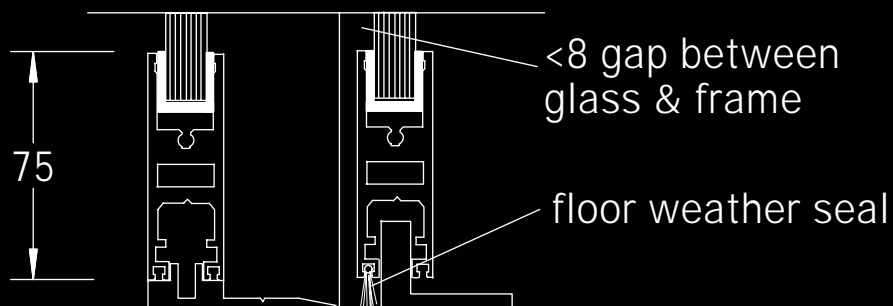
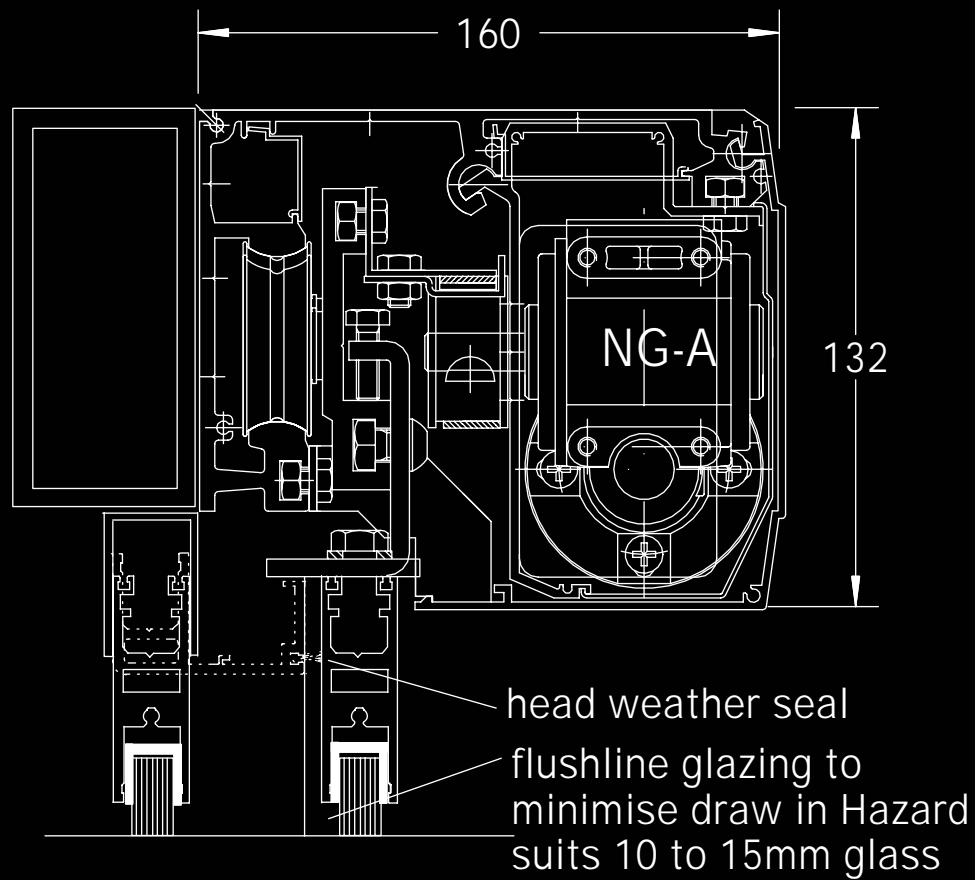

**ADIS**  
AUTOMATIC DOORS

3/413 VICTORIA STREET - WETHERILL PARK NSW 2164 AUSTRALIA

PHONE: +612 9757 4600 - FAX: +612 9757 4233

TOLL FREE: 1800 600 602

EMAIL: [INFO@AUTODOORS.COM.AU](mailto:INFO@AUTODOORS.COM.AU)

VISIT OUR WEBSITE: [WWW.AUTODOORS.COM.AU](http://WWW.AUTODOORS.COM.AU)